

Parts List

Scottoiler

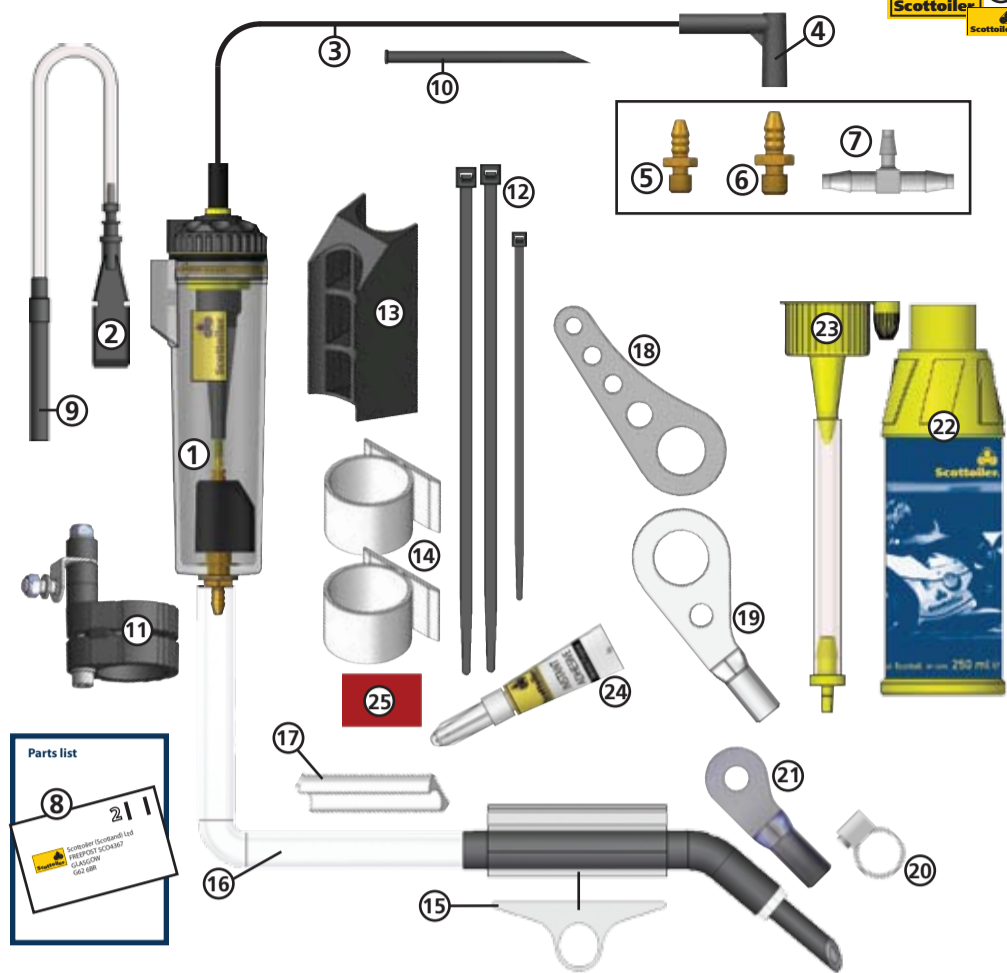

- | | |
|-----------------------------------|---------------------------------------|
| 1. RMV (Reservoir Metering Valve) | 14. RMV Mounting Sleeves (x2) |
| 2. Filler plug | 15. Dispenser Mounting Sleeves (x2) |
| 3. Vacuum Tubing (Black) | 16. Dispenser Assembly |
| 4. Vacuum Damper | 17. Conduit |
| 5. M5 Spigot | 18. Mounting Plate |
| 6. M6 Spigot | 19. Dispenser Plate |
| 7. T-Piece | 20. Dispenser Plate Clip |
| 8. Instructions and Warranty Card | 21. Small Dispenser Plate |
| 9. Breather Assembly | 22. 250ml Scotttoil |
| 10. Spare Nib (x2) | 23. Filling / Priming Spout |
| 11. RMV Clamp | 24. Instant Adhesive |
| 12. Cable ties (6 assorted) | 25. Sandpaper |
| 13. RMV Cradle | 26. Scotttoiler Stickers (3 assorted) |

Your Bike

Check www.scottoiler.com for model specific installation guides showing where and how to fit on your own bike.



Vacuum Location

RMV Position

Dispenser Routing

Some models require free of charge adapter kits in order to correctly install this kit.

Additional Parts

Where required, the additional parts will be listed on the model specific installation guide relevant to your bike, as shown above.

Found at www.scottoiler.com



How It Works

Only 3ccs of air moves back and forwards so no engine interference

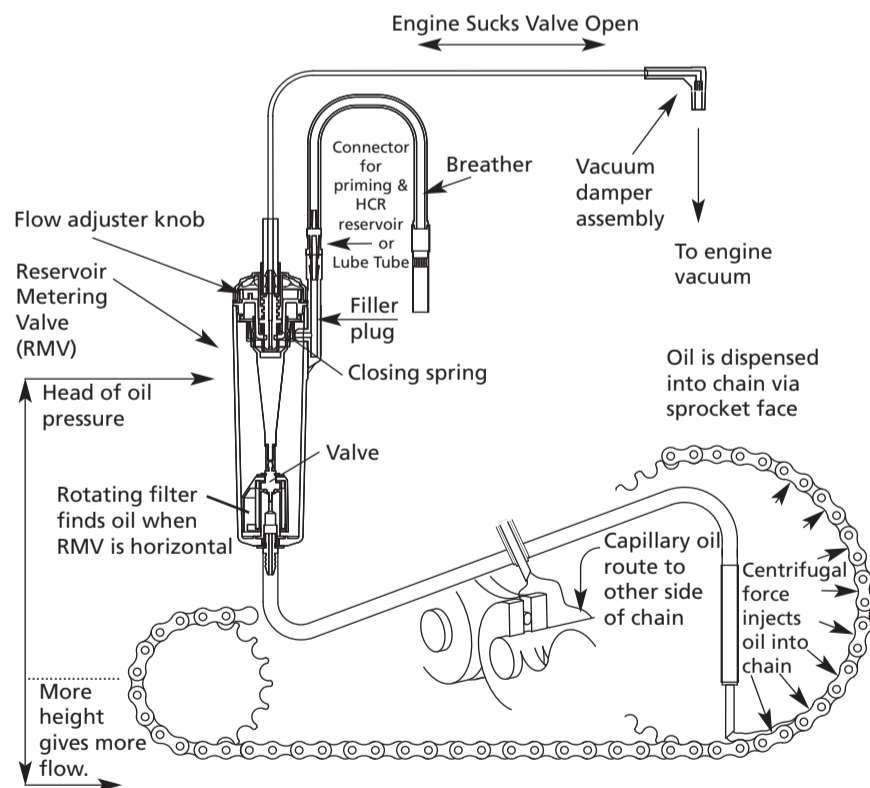

How does the Scotttoiler work? The Scotttoiler vSystem is vacuum operated. When the motorcycle engine is running vacuum is generated, this lifts a diaphragm which in turn opens the valve. Whilst open the valve allows oil to drip feed under gravity down the delivery tube to the chain via the rear sprocket. There is metering built into the valve to provide adjustment to control the rate at which oil is dispensed. It is not a pump.

How does this affect the engine? It doesn't. The Scotttoiler's output is not affected by engine speed, throttle opening and so on. The vacuum chamber is a sealed unit and does not affect the running of the bike. Upon starting the engine the valve will open, this requires 3cc of air to be moved in order to lift the diaphragm, which stays up until the engine is switched off. It is not unusual to see the diaphragm pulsating with very low revs, particularly on singles and twins, don't confuse this for a pumping action, it is not a pump.

Frequently Asked Questions (FAQ's)

- 1. Which products are suitable for my bike?** Visit our website www.scottoiler.com and select your bike 'Manufacturer' and 'Model'. Select the kit you want and download the installation guide PDF.
- 2. What oil should I use to refill my Scotttoiler?** In ambient temperatures between 0 and 20 degrees Celcius we recommend Scotttoil Traditional - Blue and in ambient temperature between 20 and 40 degrees Celcius we recommend Scotttoil High Temperature - Red. Scotttoil features a very low tack additive thus not attracting dirt. Scotttoiler cannot guarantee the compatibility of our systems using any other manufacturers oils as the materials used are tested for compatibility with Scotttoil only.
- 3. When should I refill my RMV (Reservoir Metering Valve)?** If you refill the oiler before it runs dry you won't have to prime the dispenser tube. The Reservoir Metering Valve takes around ten seconds to top up with 50ml of oil which should last approximately 400-800 miles.
- 4. Can I increase the capacity?** Yes, the Magnum High Capacity Reservoir increases capacity by up to eight times. The HCR is fitted behind the number plate and the combined increased capacity will give 4000-6000 miles between refills. Alternatively, the Lube Tube flexible high capacity reservoir increases combined capacity by up to four times. The Lube Tube can be fitted into any dead space on the bike and will mean 2000-3000 miles between refills.
- 5. Will the Scotttoiler only oil one side of my chain?** No. The oil is fed to the chain via the sprocket face where it splits over the inner side plates. Some of the oil is diverted onto the o-rings and the remainder feeds under the roller onto the bushing. Capillary action will then draw the oil across the chain. For best results load the chain with oil from the bottle or a rag after cleaning and then apply approx 1 drop per minute to maintain this film of oil.
- 6. Will I get oil on my tyre?** No, A flow rate of approximately one drop per minute applied via the sprocket face will provide an oil-film which will not pollute the running surface of the tyre and will give a dramatic improvement in chain life. In conditions where high levels of dust, sand or heavy rain are present more oil flow will be necessary to extend chain life.
- 7. Do Scotttoiler offer a fitting service?** No. If you have a new bike and are local to Glasgow give us a call, we might be looking for your bike. If you aren't confident about fitting the system, having looked at the model specific installation guide for your bike, it is recommended to use a local motorcycle dealer experienced in fitting Scotttoiler products.
- 8. I want to move my Scotttoiler onto my new bike, are the spare parts available separately?** Yes, the full range of spare parts, fittings and accessories are available online at www.scottoiler.com or by telephoning Sales on +44 (0)141 955 1100. Alternatively, contact your local Scotttoiler dealer, who can order the parts on your behalf.